

Can Cooler

TK 66 BE



Item number	26310066BE10000	Taric goods code	8418501990
EAN code	5704704014237	QTY in 40HQ	250

Short Description

Barrel coolers can also be used in places other than the retail trade, such as in the office with your own company logo, so that guests can be offered a cold water, or at trade fairs where it is easy to carry. But it is also ideal to have at home for the hot summer days and for parties, where the temperature range of 2°C -10°C is ideal for storing wine, beer, water and champagne. The TK 66 BE holds 63 liters and has a 2-piece glass tilting lid, which makes it easy to see the contents and makes it easy to get to the cold drinks. The cooler is fitted with 4 wheels, making it easy to move around, even when filled with drinks. Temperature range 2°C -10°C makes the barrel cooler perfect for cooling all kinds of drinks.

Key features

- Split flip glass lid
- 4 strong castors
- Suitable for branding
- Static cooling

Measurement Drawings

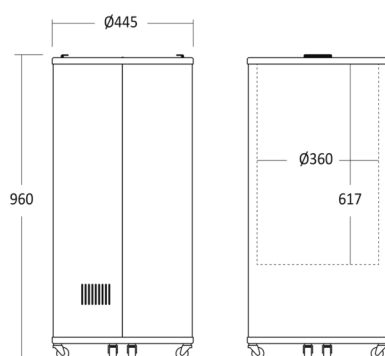

Dimensions and weight

Product dimensions, HxWxD, mm	960 x 445 x 445
Packaging dimensions, HxWxD, mm	1015 x 460 x 460
Gross- / Net volume, L	63 / 58
Internal dimensions, HxWxD, mm	617 x 360 x 360
Gross- / Net weight, kg	21 / 19

Performance and consumption

Energy efficiency class	B
Daily Energy Consumption, kWh/24	0,39
Annual energy cons. kWh/a	142
Energy Efficiency Index (EEI)	15,3
Noise level, dB(A)	50
Refrigeration / freezing technique	Static
Climate class	ST
Type of refrigerant / gas gr.	R600a / 23
Temperature range °C	0 / 10

Installation and power

Voltage / hertz, V/hz	230 / 50
Watt / Ampere, W/A	100 / 0.7
Length of Powercord, cm	200

Design and comfort

Digital display	No
Internal light	No light
External thermometer	No
Reversible door	No
Self closing door	Yes
Number of castors, pcs	4 castors

Colour and material

Inside-/outside colour	White/Black
Colour and material of door/lid	Flip glas lid

Features

scandomestic

Scandomestic A/S . Linåvej 20 . DK-8600 Silkeborg . Tel.: +45 7242 5571 . www.scandomestic.dk